

Investigation on Imitation and Presentation of RoF System Consuming Fiber Deficiencies

Yogita Pal

Research Scholar, Glocal School of Technology and Computer Science
Glocal University, Mirzapur Pole Saharanpur (U. P.) India.

Prof. (Dr.) R. Purushotham Naik

Research Supervisor, Glocal School of Technology and Computer Science
Glocal University, Mirzapur Pole Saharanpur (U.P) India.

Abstract: Radio over fiber (RoF) systems have the unique ability to connect fiber optic connections and free space in the radio. Fiber based wireless access facilitates the rapid delivery of capable multimedia services. In this research paper, the RoF system is simulated in the presence of fiber disturbances such as Polarization Mode Dispersion (PMD), Crossed Phase Modulation (XPM) and Four Wave Mixing (FWM) with the help of OptiSystem simulation tool. Changes in quality (Q factor) and bit error (BER) of the input signal with a wavelength of 1552 nm and a bit rate of 10 Gb/s were analyzed live in the presence of lines and in the absence of any damage to the fiber.

Keywords: *Radio over Fiber (RoF), Polarization Mode Dispersion (PMD), Cross Phase Modulation (XPM), Four-Wave Mixing (FWM), OptiSystem, Bit Error Rate (BER), Q factor.*

I. INTRODUCTION

Radio over Fiber (RoF) is an innovating technology which combines wired and wireless networks together to provide a solution for the demand of increasing bandwidths of the communication systems. In this technology, the light is modulated by a radio frequency signal. Its lower transmission losses and increased bandwidth along with reduced sensitivity to noise and electromagnetic (EM) interference makes it economically advantageous over other wireless transmission systems. In the RoF systems, the wireless signals are transported using fiber optic from a central station to a number of base stations and then radiated through the air, as shown in figure 1. The advantages of RoF system, namely large bandwidth, low attenuation loss, immunity to RF interference, low power consumption, etc., makes it useful in the application of video distribution systems (VDSs), cellular network, satellite control and wireless LANs among many others.

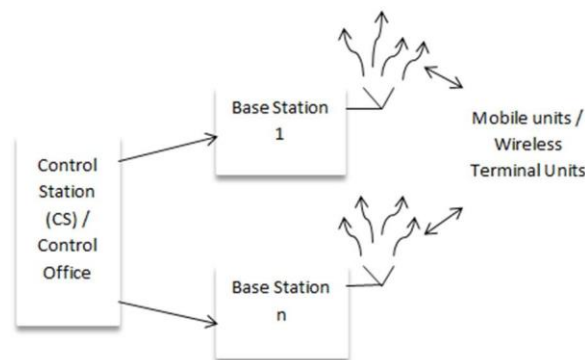

Figure 1: Radio over Fiber (RoF) system

The RoF system offers many features like attenuation loss, increased bandwidth, less interference, etc., which has improved the reliability of the system and helps in achieving high data rates. Nonetheless, it is affected by linear and non-linear fiber impairments, resulting in signal distortion.

A. Polarization Mode Dispersion (PMD)

It is one of the linear fiber impairments affecting the transmission signal. In this case, two polarized light waves which were supposed to travel at the same speed, due to the presence of imperfections and asymmetries in the fiber, now travel at different speeds. The difference gives rise to differential transit time or differential group delay for the propagated stream of data. This results in the broadening of the pulse of the output data, thereby causing degradation in the performance through inter-symbol interference.

Cross Phase Modulation (XPM)

It is non-linear fiber impairment caused due to the effect of one light wave on the phase of another light wave through the optical Kerr effect, i.e. a change caused in the refractive index of a material in the presence of an applied electric field. In a WDM system, the intensity or fluctuations in the power of an optical signal passing through an optical fiber, causes modulation in the other signals propagating with it through the phenomenon of Cross phase modulation. The XPM finds its application in areas like passive mode-locking, ultrafast optical switching, demultiplexing of OTDM channels, wavelength conversion of WDM channels, etc.

B. Four-Wave Mixing (FWM)

It is the modulation of two or more signals having different frequencies, caused by nonlinearities or time variance in a system. In WDM system using angular frequencies, the dependency of refractive index on the intensity causes shifts in phases of the waves as well as gives rise to signals at new frequencies. This is known as four-wave mixing. During FWM, the energy of the photons is not lost. The efficiency of a process is greatly affected by the phase of the signal, thus making this process a phase-sensitive one. The applications of FWM include parametric amplification, Vacuum ultraviolet light generation, generating single photons, etc.

II. SIMULATION TOOL USED

The simulation tool being used is OptiSystem 19 by OptiWave. It is an optical communication system simulation package which is used for the designing, testing and optimizing virtually any optical link present in the physical layer of the optical networks or systems. Being a system level simulator based on realistic modeling of fiber optic, it contains a powerful simulation environment. OptiSystem is used in a number of applications, e.g., CATV/WDM network design, SONET/SDH ring design, transmitter design, map design, etc.

III. SIMULATION LAYOUT AND PARAMETER SETTING

A. PMD

It can cause serious problems in high bit-rate transmissions. Here, the PMD component demonstrates the distortions caused due to PMD effects in a signal. The simulation model is shown in figure 2.

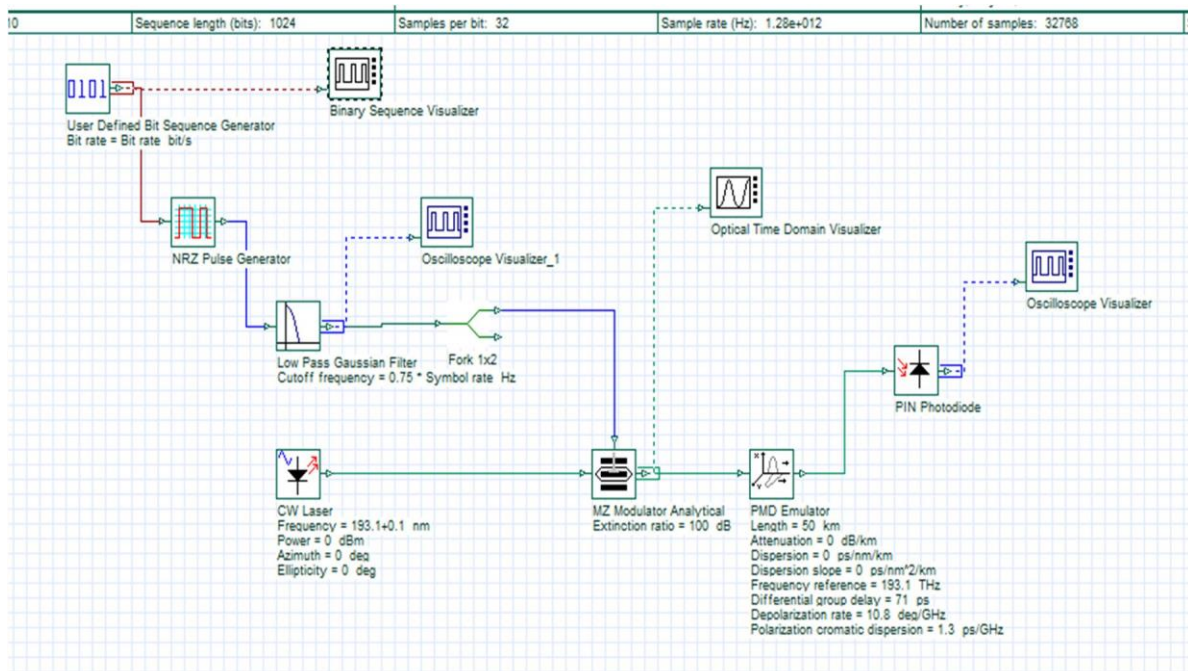

Figure 2: PMD Simulation Model

The sequence of signal pulses is simulated by the system at the rate of 10 Gb/s in a high PMD fiber. During the simulation, the attenuation and dispersion values are taken as 0. The parameters of the various components are set as in figures 3(a), 3(b), 3(c), 3(d)

and 3(e) respectively.

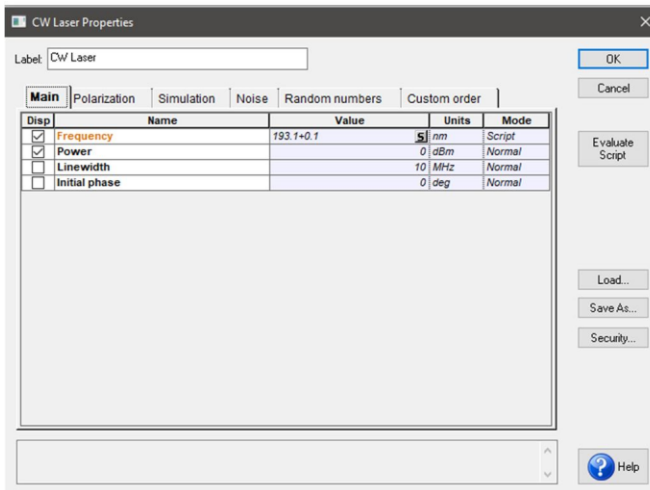

Figure 3(a): CW Laser parameters

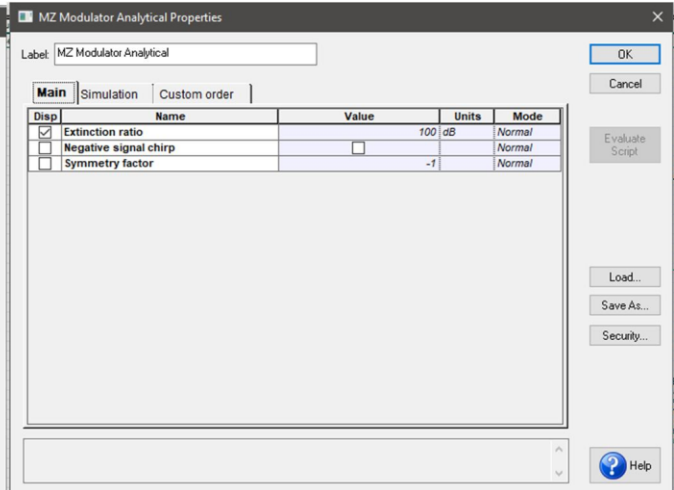

Figure 3(b): MZ Modulator Analytical parameters

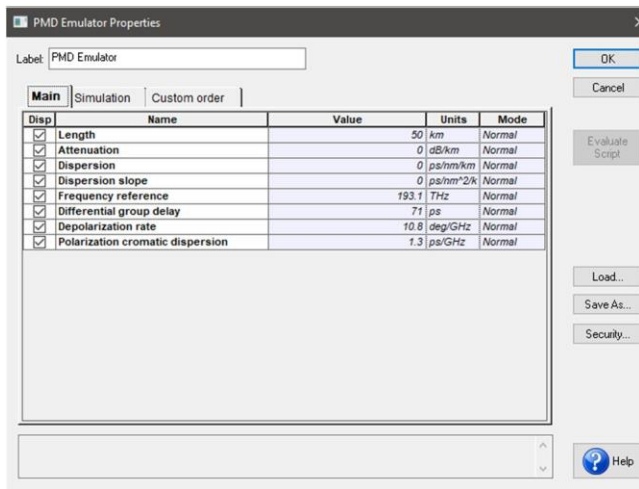

Figure 3(c): PMD Emulator parameters

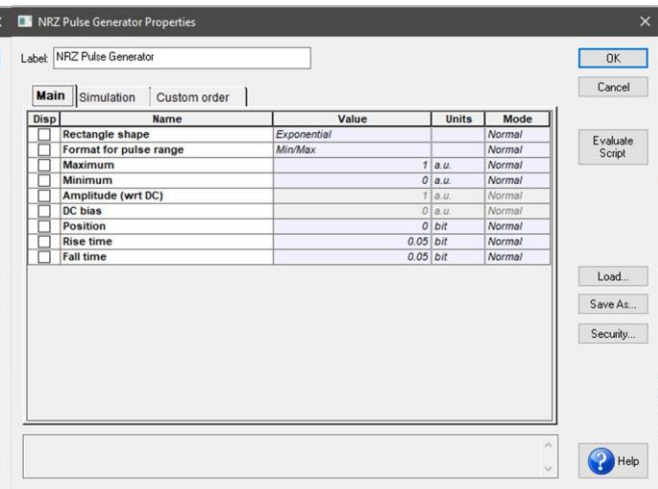

Figure 3(d): NRZ Pulse Generator parameters

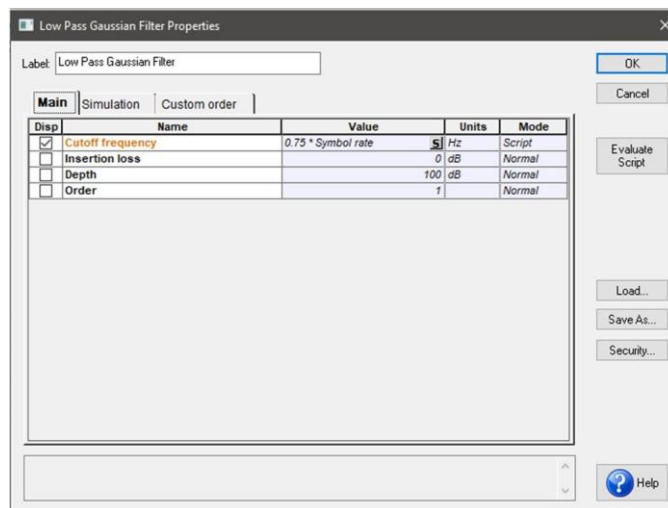

Figure 3(e): Low Pass Gaussian Filter parameters

B. XPM and FWM

The simulation layout (figure 4) and component values (figure 5(a)-5(f)) are displayed below.

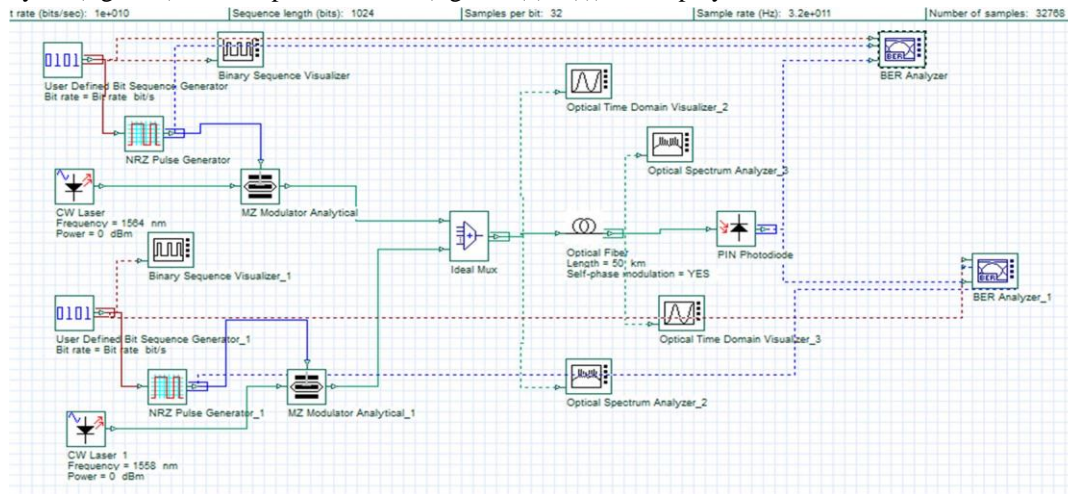

Figure 4: Layout for XPM and FWM

Disp	Name	Value	Units	Mode
<input checked="" type="checkbox"/>	Bit rate	Bit rate	bit/s	Script
<input type="checkbox"/>	Bit sequence definition	Explicit sequence		Normal
<input type="checkbox"/>	Filename	Sequence.dat		Normal
<input type="checkbox"/>	Bit sequence	0101101110		Normal
<input type="checkbox"/>	Non-zero bit locations	1		Normal
<input type="checkbox"/>	2*(N-1) Alternating zeros/ones(N)	1		Normal
<input type="checkbox"/>	Repeat every	Sequence length	bits	Script
<input type="checkbox"/>	Number of leading zeros	0		Script
<input type="checkbox"/>	Number of trailing zeros	0		Script

Figure 5(a): User Defined Bit Sequence Generator parameters

Disp	Name	Value	Units	Mode
<input checked="" type="checkbox"/>	Frequency	1552	nm	Normal
<input checked="" type="checkbox"/>	Power	0	dBm	Normal
<input type="checkbox"/>	Linewidth	10	MHz	Normal
<input type="checkbox"/>	Initial phase	0	deg	Normal

Figure 5(b): CW Laser parameters

Disp	Name	Value	Units	Mode
<input checked="" type="checkbox"/>	Bit rate	Bit rate	bit/s	Script
<input type="checkbox"/>	Bit sequence definition	Explicit sequence		Normal
<input type="checkbox"/>	Filename	Sequence.dat		Normal
<input type="checkbox"/>	Bit sequence	1001011000		Normal
<input type="checkbox"/>	Non-zero bit locations	1		Normal
<input type="checkbox"/>	2*(N-1) Alternating zeros/ones(N)	1		Normal
<input type="checkbox"/>	Repeat every	Sequence length	bits	Script
<input type="checkbox"/>	Number of leading zeros	0		Script
<input type="checkbox"/>	Number of trailing zeros	0		Script

Figure 5(c): User Defined Bit Sequence Generator 1 parameters

Disp	Name	Value	Units	Mode
<input type="checkbox"/>	Extinction ratio	100	dB	Normal
<input type="checkbox"/>	Negative signal chirp			Normal
<input type="checkbox"/>	Symmetry factor	-1		Normal

Figure 5(d): MZ Modulator Analytical parameters

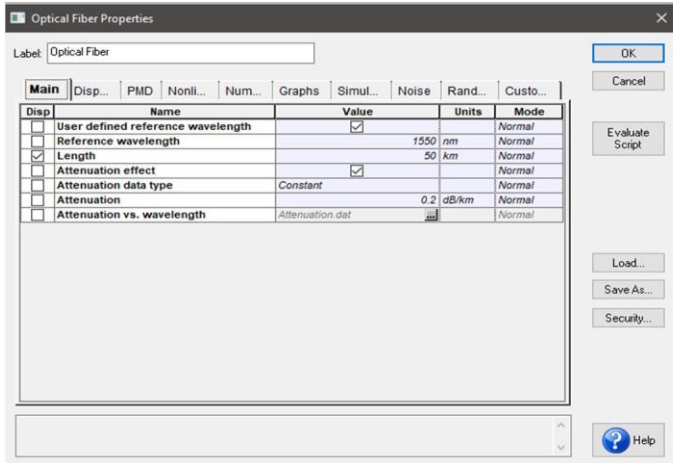

Figure 5(e): Optical fiber parameters

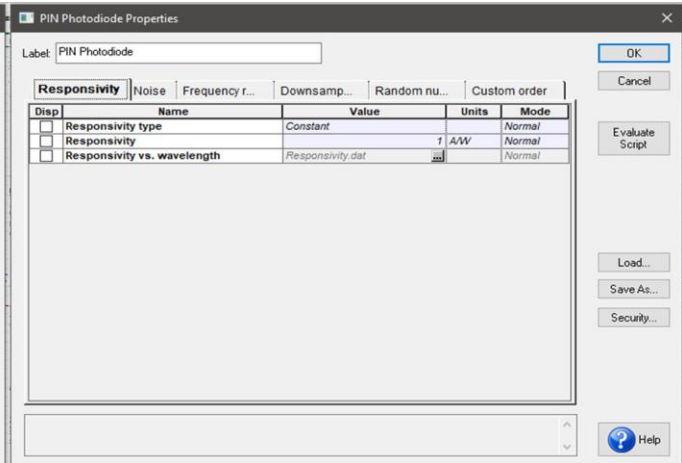

Figure 5(f): PIN Photodiode parameters

IV. INPUT WAVEFORMS

A. PMD

The User Defined Bit Sequence Generator is used to generate a bit sequence as displayed using Binary Sequence Visualizer in figure 6(a). The input signal is a sequence of NRZ pulses after passing through a Low Pass Gaussian Filter as shown in figure 6(b) with the help of an Oscilloscope Visualizer.

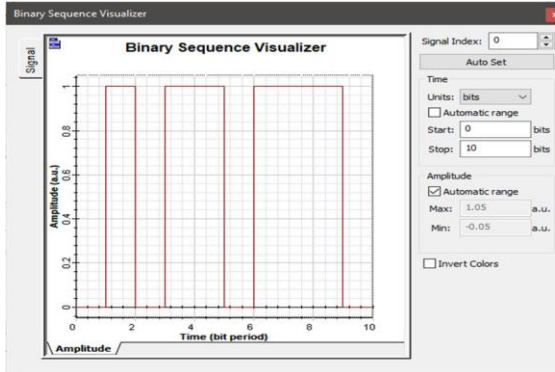

Figure 6(a): Bit sequence generated by the User Defined Bit Sequence Generator

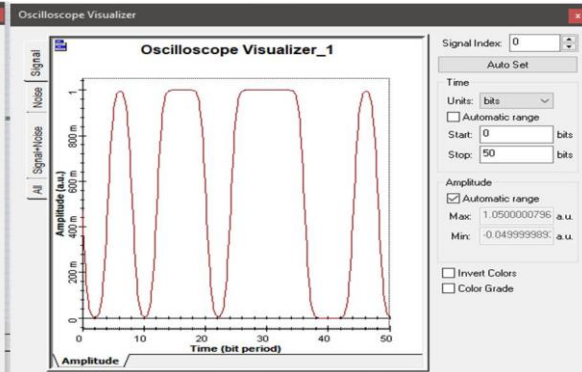

Figure 6(b): Input sequence of pulses

B. XPM and FWM

Two Binary Sequence Visualizers are used to generate two different bit sequences for inputs. The generated sequence is then passes to MZ Modulator Analytical for the further processing steps.

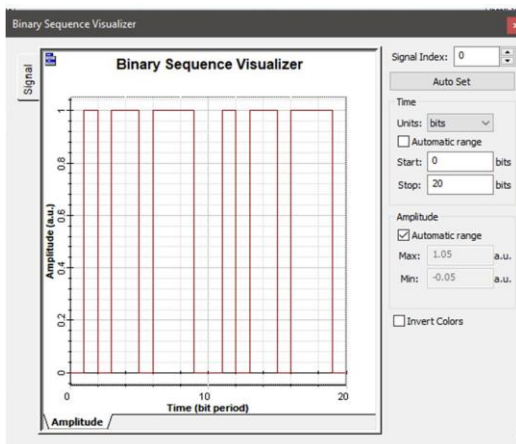

Figure 7(a): Bit sequence generated for input 1

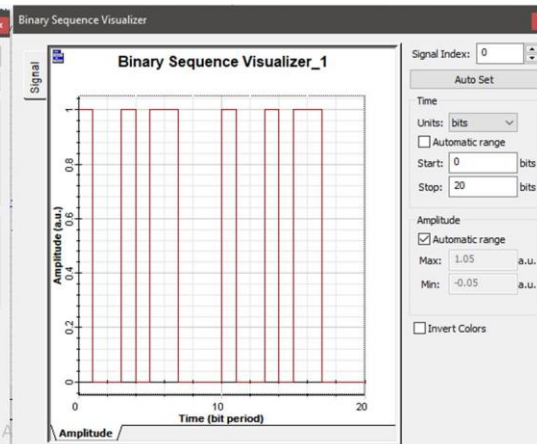

Figure 7(b): Bit sequence generated for input 2

V. RESULTS

A. PMD

The simulations are carried out for the polarized optical signal and the resultant sequence is obtained. Figure 8(a) shows the resultant output signal as observed by using an Oscilloscope Visualizer. Figure 8(b) shows the output of BER Analyzer displaying Q factor and minimum BER values.

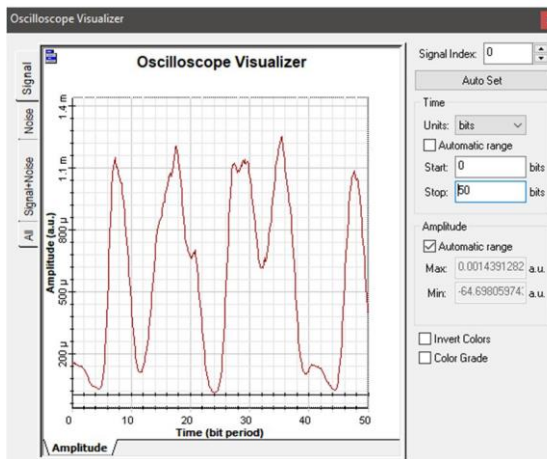

Figure 8(a): The resultant output signal

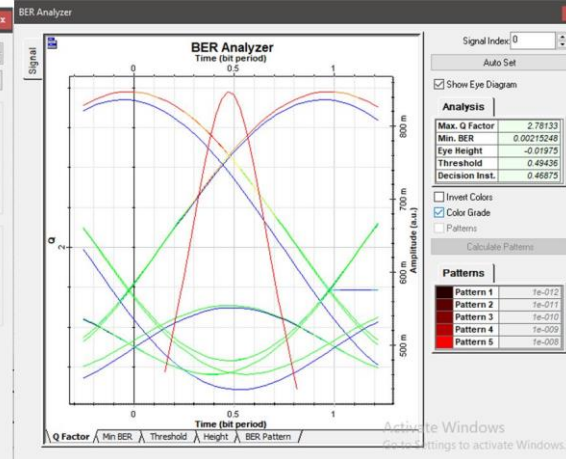

Figure 8(b): The result of BER Analyzer for PMD

The presence of excess of power at 1's and the presence of energy at 0's in the resultant output of PMD is due to the imperfect cancellation of the pulses combining together on the orthogonal axis. The distortion effect is caused due to the depolarization rate coefficient, since the polarization chromatic dispersion is too small to create a substantial deformation of the output signal. There is also broadening of signal in this case.

B. XPM and FWM

The resultant output is with some distortions in the signal caused due to the interference of cross phase modulation and four-wave mixing in the transmitted signal.

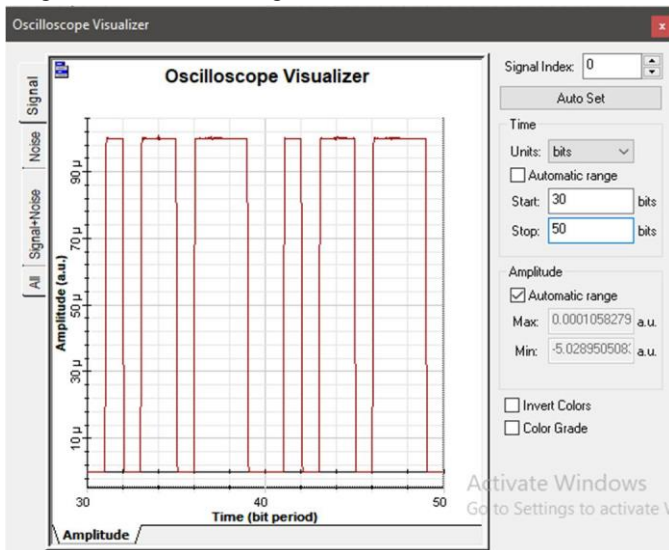

Figure 9(a): The resultant output signal

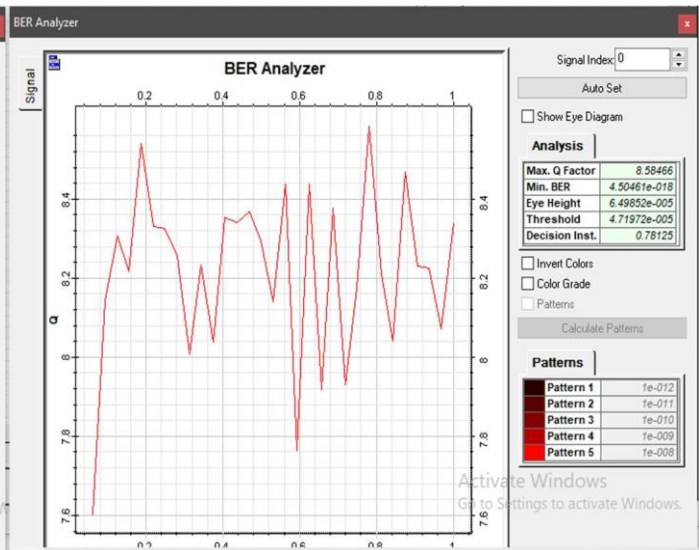

Figure 9(b): The result of BER Analyzer for XPM and FWM

VI. CONCLUSION

In this paper, the simulation and analyzation of the RoF system in the presence of PMD, XPM and FWM fiber impairments for 1552 nm wavelength at 10 Gb/s bit rate has been performed. It is observed that XPM and FWM model causes less dispersion and distortion as compared to the PMD model and also offer a greater Q factor and less BER value than the latter.

REFERENCES

- [1] J. Johny and S. Shashidharan, "Design and simulation of a Radio Over Fiber system and its performance analysis," 2012 IV International Conference on Ultra Modern Telecommunications and Control Systems, 2012, pp. 636-639, doi: [10.1109/ICUMT.2012.6459744](https://doi.org/10.1109/ICUMT.2012.6459744).
- [2] A. Seal, S. Bhutani and A. Sangeetha, "Performance Analysis of Radio over Fiber (RoF) System for Indoor Applications," 2017 International Conference on Technical Advancements in Computers and Communications (ICTACC), 2017, pp. 73-76, doi: [10.1109/ICTACC.2017.28](https://doi.org/10.1109/ICTACC.2017.28).
- [3] Musa, Ahmed, Bany Salameh, Haytham and Olaimat, Ayat. "Simulation-Based Optical Threshold Component Design for Mitigating Four-Wave Mixing Effects in WDM Radio Over Fiber Systems" Journal of Optical Communications, vol. 41, no. 4, 2020, pp. 429-436, doi: [10.1515/joc-2017-0212](https://doi.org/10.1515/joc-2017-0212).
- [4] Calvin C.K. Chan, Optical Performance Monitoring, Academic Press, 2010, pp. 67-99, ISBN 9780123749505, doi: [10.1016/B978-0-12-374950-5.00003-1](https://doi.org/10.1016/B978-0-12-374950-5.00003-1).
- [5] Kathpal, Namita and Garg, Amit Kumar. "Parametric Analysis of Self-Phase Modulation in Single-Tone RoF System" Journal of Optical Communications, vol. 42, no. 2, 2021, pp. 357-364, doi: [10.1515/joc-2018-0101](https://doi.org/10.1515/joc-2018-0101).
- [6] Nain, Abhimanyu, Kumar, Suresh and Singla, Shelly. "Impact of XPM Crosstalk on SCM-Based RoF Systems" Journal of Optical Communications, vol. 38, no. 3, 2017, pp. 319-324, doi: [10.1515/joc-2016-0045](https://doi.org/10.1515/joc-2016-0045).
- [7] Meenakshi Sharma, "Investigating the Q-factor and BER of a WDM System in Optical Fiber Communication using Different Modulation Formats at Different Wavelengths" International Journal of Engineering Research & Technology, vol. 4, no. 2, 2015, pp. 625-628 .
- [8] F. Forghieri, R. W. Tkach, and A. R. Chraplyvy in: Optical Fiber Telecommunications vol. IIIa ed. I. Kaminow and T. Koch, chapter "Fiber Nonlinearities and their impact on Transmission Systems".
- [9] Marcuse, A. R. Chraplyvy, and R. W. Tkach, Journ. Lightwave Technol, 9, 121 (1991).
- [10] Cristian Francia, Frank Bruyere, Denis Penninckx, and Michel Chbat, "PMD Second-Order Effects on Pulse Propagation in Single-Model Optical Fibers" IEEE Photonics Technology Letters, December 1998.
- [11] L. E. Nelson, R. M. Jopson, H. Kogelnik, and G. J. Foschini, "Measurement of Depolarization and Scaling Associated with Second Order Polarization Mode Dispersion in Optical fibers" IEEE Photonics Technology letters, December 1999.